

AU-M3000: Flash Controller Core

The AU-M3000 Flash Controller Core is a versatile NAND/NOR flash controller that supports various types of NAND and NOR flash chips from several manufacturers. The Flash Controller data bus width is user configurable to 8, 16, 32 or 64 bits. The Flash Controller supports NAND flash memory systems from 8 Mbytes to 16 Gbytes, and NOR flash memory systems from 512 Kbytes to 1 Gbyte. Flash chip timing parameters are both user configurable at reset with Verilog parameters and software programmable to support a wide range of flash speed grades and system clock frequencies. The Flash Controller is available as a synthesizable Verilog model from Aurora VLSI, Inc. Contact CustomerService@auroravlsi.com.

The Flash Controller supports the Read, Program, Erase, Read Status, Read ID, Copy Back, and Reset NAND flash commands. ECC support is provided for NAND flash systems. NOR flash commands that are supported include Read, Program, Erase, Read Status, Read ID, Read CFI, Clear Status, Buffered Write, Lock, Unlock, and Lock Down.

In NAND flash systems, configurable features include page size, data bus width, flash chip size, number of flash banks, interrupt enable, ECC functionality, copy back functionality, command confirmation, number of address cycles, number of ID read cycles, spare area usage, and address[33:32]. Configurable features for NOR flash systems include, data bus width, flash chip size, number of flash banks, interrupt enable, block size, boot block configuration, lock feature, burst read feature, buffered write feature, and the CFI feature. Configurable features have hardwired values upon reset that are user configurable with Verilog parameters. After reset, they can be reconfigured by software.

Flash timing parameters at reset are hardwired to user configurable values. After reset, they are software programmable. This allows the Flash Controller to be used for boot code at reset with a wide range of flash speed grades and system cycle times. After booting, performance can be optimized by reconfiguring the flash timing parameters for the specific flash chips that are used and the system clock frequency.

The host processor initiates flash chip operations by writing commands to the Flash Controller. When a flash chip operation completes, the Flash Controller optionally signals a maskable interrupt to the host processor. The host processor may also poll Flash Controller registers to determine when a flash chip operation has completed.



Flash Controller features are summarized:

- NAND and NOR flash controller
- 1, 2, or 4 banks of flash chips
- 8 bit, 16 bit, 32 bit, or 64 bit Flash Controller data bus
- 8 Mbyte to 16 Gbyte NAND flash memory systems
- 512 Kbyte to 1 Gbyte NOR flash memory systems
- User configurable reset values and fully programmable flash chip timing parameters
- NAND flash
 - Read, Program, Erase, Read Status, Read ID, Copy Back, and Reset
 - 64 Mbit to 8 Gbit flash chips- configurable
 - 8 bit or 16 bit flash chip data bus- configurable
 - 512 byte or 2048 byte page size- configurable
 - ECC hardware support
 - spare area usage- configurable
 - 2 or 4 cycle ID register read- configurable
- NOR flash
 - Read, Program, Erase, Read Status, Read ID, Read CFI, Clear Status, Buffered Write, Lock, Unlock, and Lock Down
 - 4 Mbit to 512 Mbit flash chips- configurable
 - 8 bit or 16 bit flash chip data bus- configurable
 - 64 Kbyte or 128 Kbyte main block size- configurable
 - top, bottom, or no boot block- configurable
 - 8 Kbyte, 16 Kbyte, or 32 Kbyte boot block size- configurable
- Interrupt or host processor polling for flash command completion

The Flash Controller supports one, two, or four flash banks through its flash chip enable outputs- flash_ce[3:0]. The flash data bus and control lines are common to all flash banks.

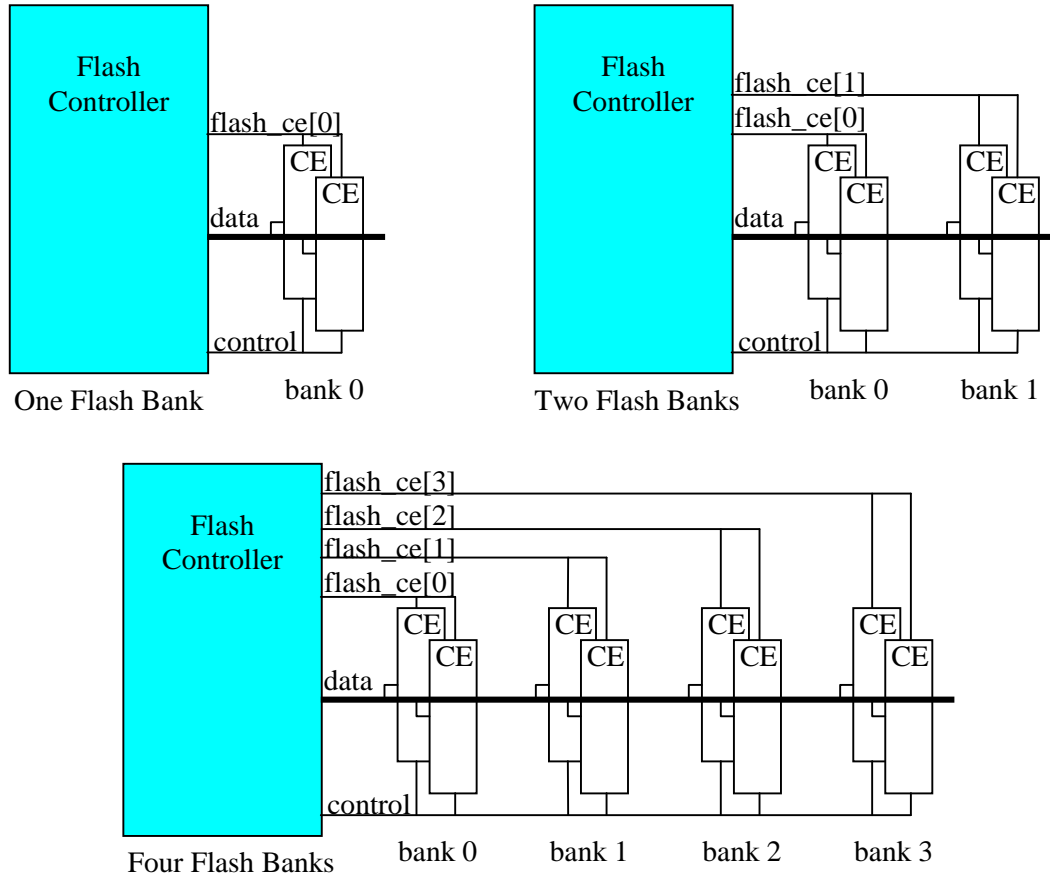

The core is delivered as a synthesizable RTL Verilog model. Deliverables include:

- RTL Verilog source code model of the core
- Verilog testbench and test cases
- Synthesis scripts examples
- Complete detailed documentation and training class notes